



5/2 Forsyth Street GLEBE NSW

1  1  1 

A rare opportunity to secure a generously proportioned studio apartment with balcony and parking in a sought after Glebe Point location. This comfortably appointed apartment enjoys a perfect northerly orientation with a leafy outlook and has all amenities at your doorstep. The property is currently leased to a reliable long term tenant offering immediate returns to investors.

Type : House
Building Size : 39 sqm
Land Size : 52 sqm
View : <https://www.recoproperty.com.au/8065581>

- * Open, light filled studio space opening onto balcony with leafy outlook
- * Separate well appointed kitchen
- * Large built-in storage
- * Comfortable bathroom with full bath
- * Internal laundry facility

[For full version visit the website](#)

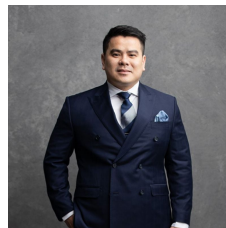

Junianto Lianto
02 8357 3377

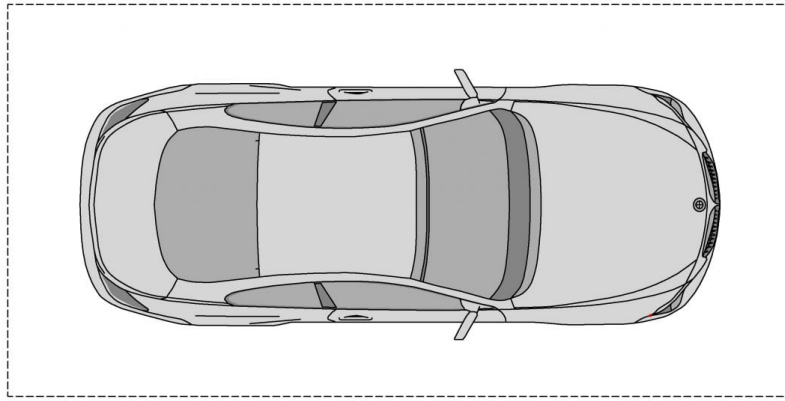

CARSPACE

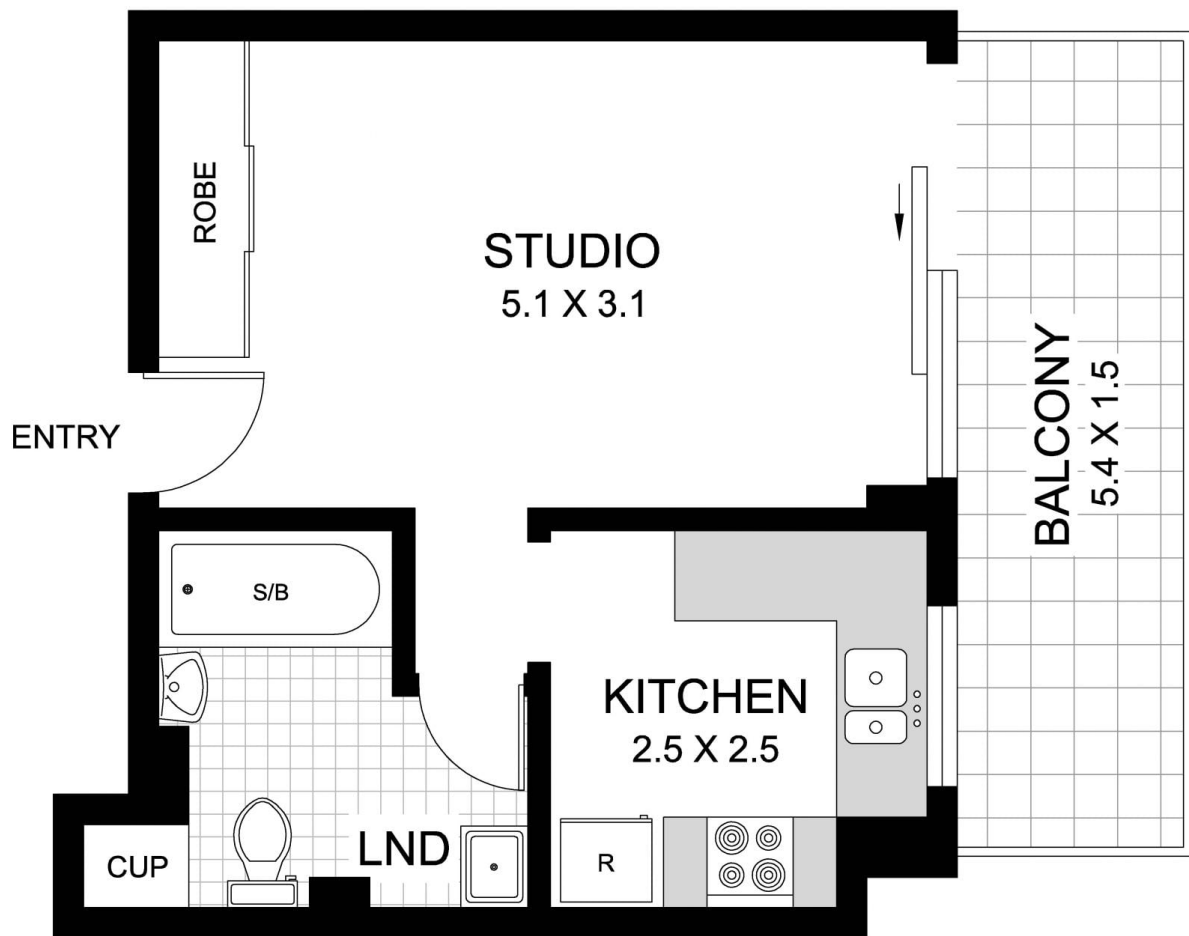

This plan is for illustrative purposes only and dimensions are approximate. It does not constitute part of any legal document or commercial contract for the sale or lease of this property.

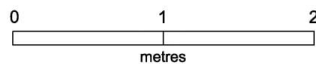

5/2 FORSYTH STREET
GLEBE