



51/51 Hereford Street GLEBE NSW

1  1 

This is a great opportunity to secure an affordable property investment with a reliable rental yield or a great city fringe base in an ever popular location, exceptionally convenient to the best of Glebe lifestyle. A fresh easy-care, light and bright apartment, positioned mid-floor of a well managed and maintained security block.

- * Recently refurbished with new kitchen
- * Private balcony with a peaceful leafy outlook
- * Secure undercover car space
- * Stunning roof top pool, outdoor BBQ area with city views
- * Easy walk to Glebe Village cafes, transport options, University precincts, RPAH

Type : Studio

View : <https://www.recoproperty.com.au/8065612>



Junianto Lianto
02 8357 3377

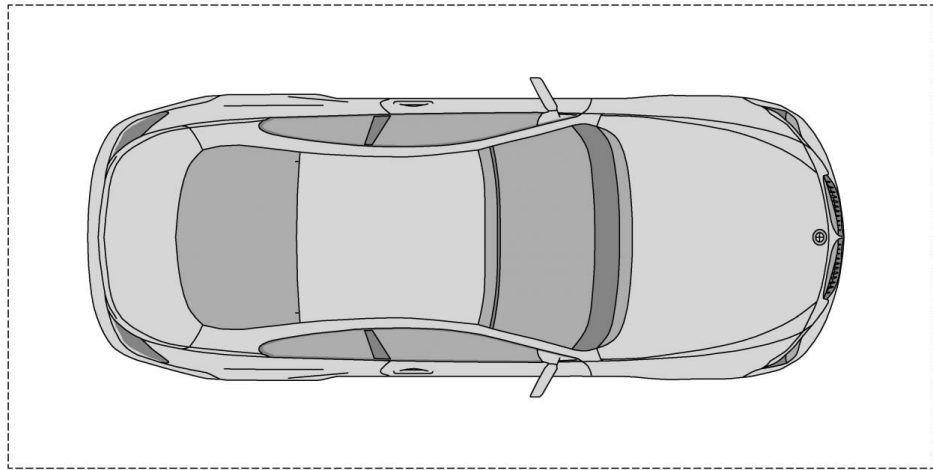
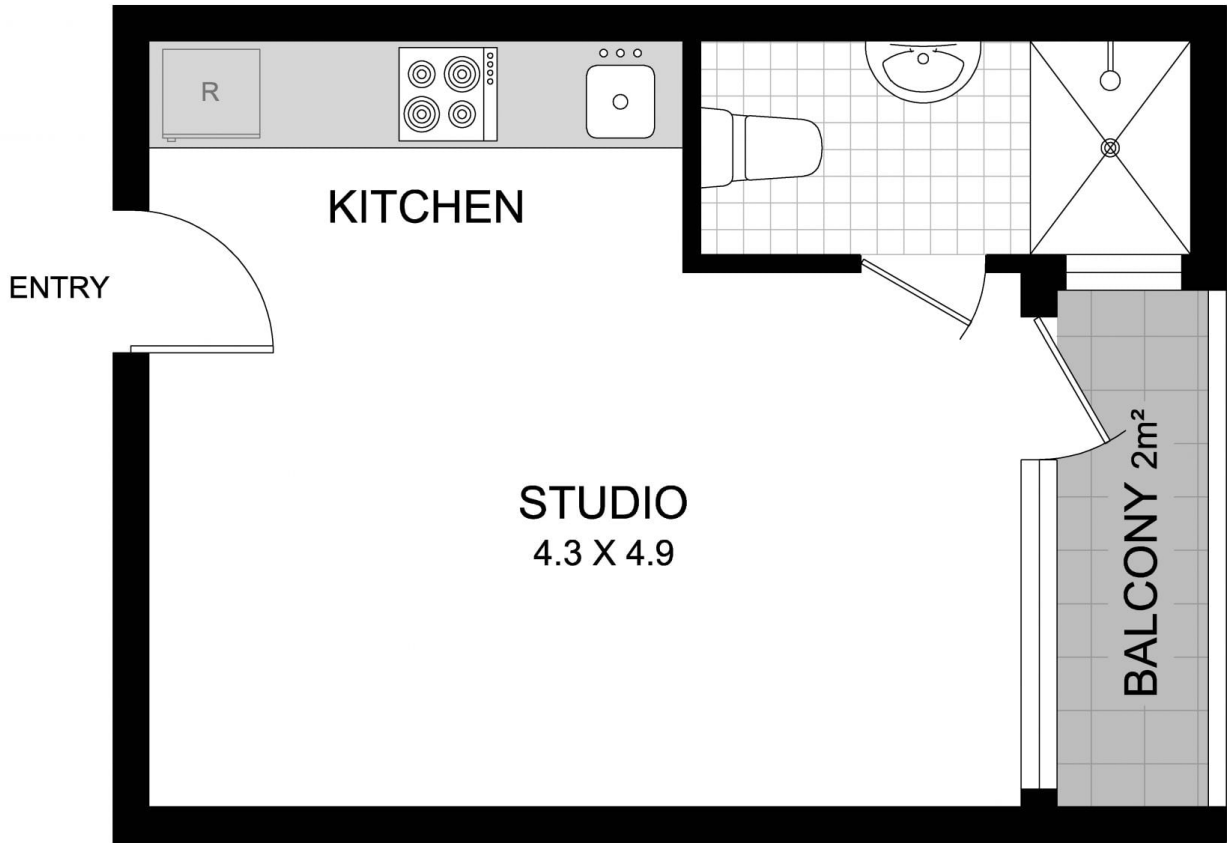

SECURITY CARSPACE

This plan is for illustrative purposes only and dimensions are approximate. It does not constitute part of any legal document or commercial contract for the sale or lease of this property.

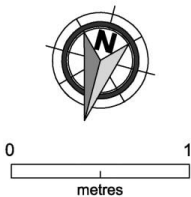

**51/51 HEREFORD STREET
GLEBE**